

# MERMAC U

## Multipurpose underwater winch



The MERMAC U underwater winch system is available with several purpose-built features and options, making it an ideal choice for use within the ocean science and defence industries.

The MERMAC U includes advanced technology and builds on decades of extensive MacArtney winch design, manufacturing experience and know-how. It provides an innovative system solution with a robust design, fully equipped for subsea challenges.

Manufactured as standard from stainless steel, purposefully selected for underwater use, the MERMAC U provides a low-complexity system that utilises industry-standard components with encapsulated motors.

The MERMAC U is designed to operate in harsh underwater marine environments. The winch can be additionally equipped with steel-armoured and PUR jacket cables.

Rated for deployment at depths of up to 750 m, the underwater winch system comes with an intelligent control system offering flexible operation for measuring and monitoring. It is capable of launching and retrieving an extensive range of underwater sensor packages at programmed intervals and predefined depths.

Extended service inspections offered.

### Features and benefits

- Compact
- Simple installation
- Adjustment and maintenance simplicity
- Low complexity
- Multiple cable layers
- Surface piercing capability

### Applications

- Climate change studies
- Environmental monitoring
- Surveillance/survey systems
- Online calibration of diver detection systems

### Options

- Wide range of materials
- Protective cage
- Data package with malfunction/anomaly alert
- Skid mount for fixed winch positioning
- Integration with deep-sea observatories

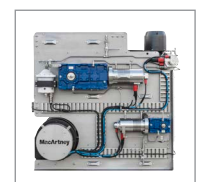

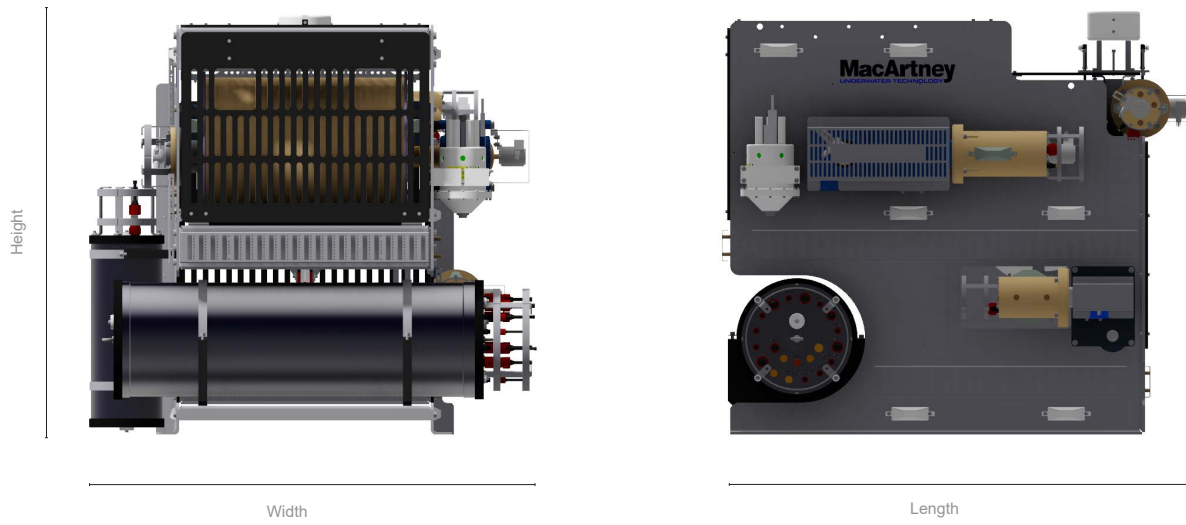

### Specifications

model	Winch dimensions (width/length/height) mm	Cable OD mm	Cable capacity m	Winch weight (in air) kg	Max pull kg	Speed (layer 1) m/min	Power supply VDC
MERMAC U	1550/1550/1460	12	750	1300	300	15	560